

OPERATION AND MAINTENANCE MANUAL, DART CHECK VALVE

Rev	ECN No.	Date	Reviewed By	Approved By	Status
A	5016676	06-DEC-2006	Darby, Scott A.	Douglas, Don	RELEASED

Summary: Operating and Maintenance instructions for the Weco® Dart Check Valve.

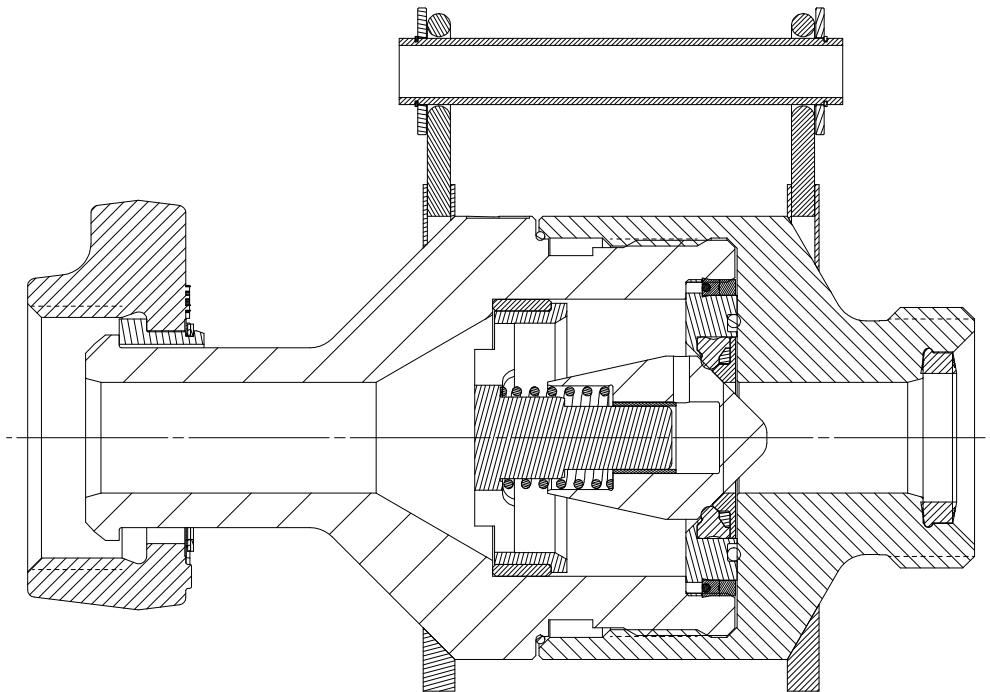

NOTES:

Weco® Dart Check Valves

Operating and Maintenance Instructions

1-1/2" 15,000 PSI, 2" 15,000 PSI, 3" 15,000 PSI

CLEAN SERVICE

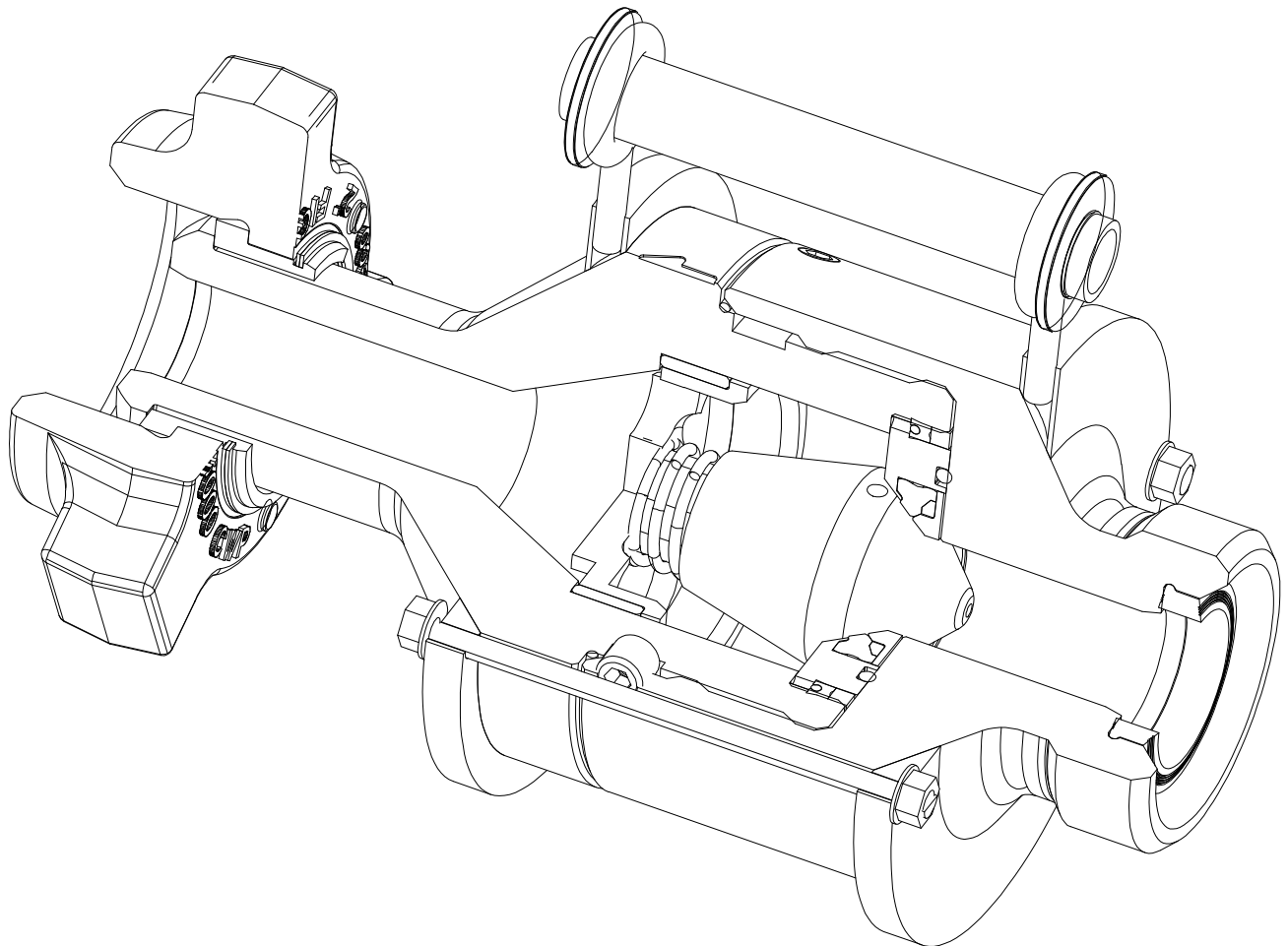

1.0 WARNINGS

FMC cannot anticipate all of the situations a user may encounter while installing and using FMC products. Therefore, the user of FMC products **MUST** know and follow all applicable industry specifications on the safe installation and use of these products. Refer to the FMC product catalogs, product brochures and installation, operating and maintenance manuals for additional safety information or contact FMC at 800-772-8582.



FAILURE TO FOLLOW THESE WARNINGS COULD RESULT IN SERIOUS INJURY OR DEATH!

WARNING

1. Do not mix or assemble components, parts, or end connections with different pressure ratings. Mismatched parts may fail under pressure.
2. Do not use or substitute non-FMC components or parts in FMC products and assemblies.
3. Do not strike, tighten, loosen pressurized components or connections.
4. Do not exceed the rated working pressure or temperature rating of the product.
5. Complete and proper make-up of components and connections is required to attain rated working pressure.
6. Do not use severely worn, eroded, or corroded products. Contact FMC for more information on how to identify the limits of erosion and corrosion.
7. Follow safe practices when using products in overhead applications. Products not properly secured could fall.
8. Select one appropriate product and materials for the intended service.

9. Do not expose standard service products to sour gas fluids. (Refer to NACE MR0175). Do not interchange sour gas with standard service components.
10. Use appropriate safety precautions when working with ferrous products below freezing temperatures. Freezing temperatures lower the impact strength of ferrous materials.
11. Follow manufacturers instructions and Material Safety Data Sheet directions when using solvents.
12. Make certain that personnel and facilities are protected from residual hazardous fluids before disassembly of any product.
13. If any leakage is detected from FMC products, remove them from service immediately to prevent potential damage and personal injury.

2.0 SAFETY INSTRUCTIONS

The applications of FMC products are in working environments where general personnel safety procedures and policies **MUST** be followed. Always use appropriate protective equipment in high pressure, extreme temperature or severe service applications.

3.0 OPERATING INSTRUCTIONS

Weco Dart Check Valves are used as isolation valves. Full flow is allowed through the valve in the designated flow direction while flow is prevented through the valve in the opposite flow direction.

1. Prior to installation, Weco Dart Check Valves should be inspected for proper operation and orientation. The valve should be free of contamination and the dart head should move with less than 30 lb of force applied. The seat should be inspected prior to use for signs of erosion.
2. It is very important to verify the check valve's flow direction. The check valve is unidirectional. To identify flow direction, the dart check valve has an arrow engraved on the top to

indicate flow direction. Additionally, the dart head may be observed in the flow bore when out of the flowline.



If the check valve is installed the wrong way in a flow line, the flow in the intended direction will be shut off and this could result in a very hazardous condition.

WARNING



Never look into the valve bore while the valve is in a flowline. Pressure and fluids could escape from the valve causing bodily injury.

WARNING

3. The dart check valve may be installed in any orientation since it does not depend on gravity to bias the checking mechanism. The dart head is spring energized and will provide a checking seal in any valve orientation. The dart check valve is provided with a handle that can aid in handling and installation.



The handle provided with the dart check valve is intended for the sole purpose of handling the valve while it is out of the flowline. **DO NOT** use the handle to lift loads other than the dart check valve. **DO NOT** attempt to lift the dart check valve by the handle while the valve is still connected to any other equipment.

WARNING

4. The dart check valve should be thoroughly flushed with clean fresh water after each use and the bore of the valve should be sprayed with a light oil or comparable corrosion inhibitor. Flush the valve by connecting a water supply to the upstream side of the valve and providing enough water pressure to open the dart head.

5. To prevent leakage, malfunctions resulting from internal wear or seal degradation, the user must establish a preventative maintenance and inspection program. This program must include:
 1. Inspection or parts to detect loss of wall thickness which may result in decreased pressure capacity.
 2. Routine replacement of seals and inspection of proper operation.

4.0 MAINTENANCE INSTRUCTIONS

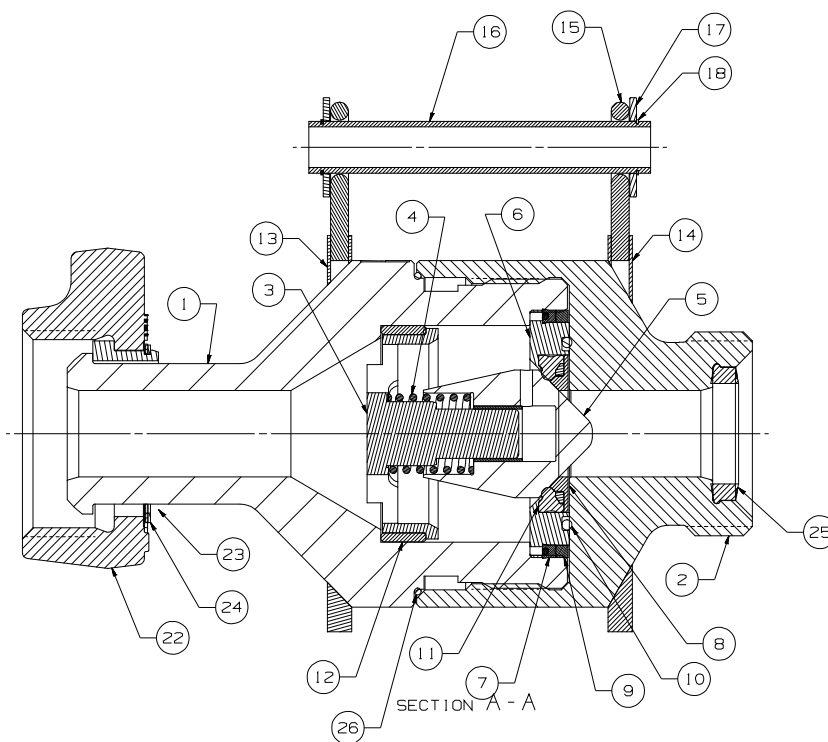

ITEM	DESCRIPTION	QTY
1	BODY	1
2	ADAPTER BODY	1
3	STEM	1
4	SPRING	1
5	DART HEAD ASSEMBLY	1
6	SEAT	1
7	POLYPAK	1
8	SEAT RETAINER	1
9	SPACER	1
10	O-RING	1
11	MOLDED SEAL	1
12	SHOULDER RING	1
13	PLATE, HANDLE, BODY	1
14	PLATE, HANDLE, ADAPTER BODY	1
15	EYEBOLT, HANDLE	2
16	TUBE, HANDLE	1
17	WASHER, HANDLE	2
18	RETAINING RING, SPIROLOX, HANDLE	2
19	NUT, HANDLE	4
20	STUD, HANDLE	2
21	SET SCREW, 5/8"-11 X 5/8"	6
22	DETACHABLE NUT	1
23	RETAINER SEGMENT	3
24	RETAINING RING	1
25	SEAL RING	1
26	O-RING	1

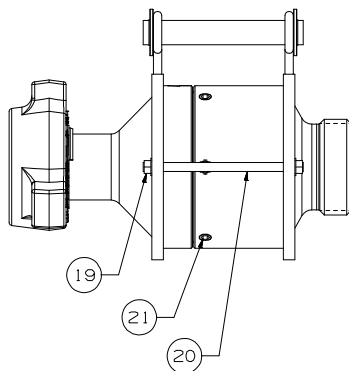

4.1 Required Tools

Light lubricant, anti-seize or equivalent, rubber mallet, wooden stick, chain or strap wrench, Allen wrenches, flat blade screwdriver, socket wrench

4.2 Disassembly

1. Remove the Weco Dart Check Valve from service and verify that all the pressure is bled from the valve.
2. Remove the handle assembly by removing two of the four locknuts attached to the threaded studs and one of the two spirolox retaining rings attached to the ends of the handle.
3. Remove the six set screws in the body which lock the body and body adapter together.
4. Secure the body adapter of the check valve in a vise or with a chain tong or equivalent. Take care not to damage the end connections and clamp on the body adapter only so that the body is free to be turned.
5. With a chain or strap wrench wrapped around the body OD, turn the body. Remove the body from the body adapter. Make sure no internal parts fall out when separating the body from the body adapter.
6. Remove the seat retainer.
7. Insert a mallet handle or wooden stick into the body end connection bore, such that it rests on the seat. The handle or stick must be of small enough diameter to pass through the flow bypass holes of the stem. Gently tap the stick to drive the seat out of the body. Gradually tap the seat out by moving the location of the stick between taps. Take care to protect the seat as it comes out of the body; do not let it fall out of the body. An O-ring, spacer ring, seat seal and polypak will come out along with the seat.
8. Remove the dart head, the coil spring, and the stem.
9. Clean and inspect all parts. NOTE: Do not soak elastomers in solvents.

10. Inspect body and body adapter for corrosion and erosion. Inspect the seat and dart head for pitting or signs of erosion. Inspect the bushing in the dart head for wear. Replace all elastomers and parts that indicate excessive wear or damage.

4.3 Assembly

1. Check/verify parts against bill of material and clean all parts and inspect for nicks or burrs.
2. Stand body on end so that you are looking into the body cavity.
3. Apply grease to the ID of the stem sleeve that is still in the body and all of the outer diameters of the stem and insert the stem into the stem sleeve until it bottoms out.
4. Apply grease to the ID and OD of the helical coil spring and insert it onto the stem that is inside the body cavity.
5. Apply grease to the ID of the bushing of the dart head subassembly and insert it onto the stem in the body cavity, it should slightly compress the helical coil spring.
6. Apply grease to the molded seat seal and insert it into the seat.
7. Place the seat over the top of the dart head with the beveled seat face pointing down towards the dart head.
8. Apply grease to the OD and ID of the polypak seal, the OD of the seat and body cavity. While pushing down on the seat and compressing the helical coil spring until the seat bottoms out, install the polypak by gradually working it between the seat and the body cavity. Be careful not to pinch or bind the polypak.
9. Apply grease to the OD and ID of the spacer ring and insert it over the top of the polypak until it is flush with the top surface of the seat. It may be necessary to use a rubber mallet to orient the spacer ring to the correct position.
10. Apply grease to the seat retainer and install into the bore on the seat.

11. Verify/clean the face seal groove in the seat. Apply grease to the groove and install the face O-ring into the seat. Apply additional grease to the O-ring to insure that it stays in place when the valve is later re-oriented for final tightening.
12. Lightly lubricate and install the environmental O-ring over the body threads and set screws relief to the corner of the body shoulder, taking care not to nick the seal on the threads or set screw relief.
13. Heavily lubricate with anti-seize or equivalent the body ACME threads.
14. Install the body adapter on the body, starting by hand. Hand-tighten the adapter body as far as possible with the valve still standing vertically on end. The adapter body needs to be almost touching the seat's face seal O-ring to insure that the internal components stay in place while performing the final make-up torque. Make up the body adapter end connection or secure it in a vise. Apply approximately 1000 ft-lb make up torque between the body and body adapter by using a chain/strap wrench and cheater bar or equivalent on the body end connection. Be sure the body adapter has fully seated against the seat and that the seat has been driven completely into the body. There should be 1/32 to 1/16 inch gap between the body and body adapter if properly made up.
15. Look through the set screw holes in the body to ensure proper alignment. The set screw relief should be aligned with the body adapter set screw holes. Apply anti-seize to the threads of the set screws. Loosely install all the set screws into the adapter body. Tighten one set screw then tighten another on the opposite side. Complete this sequence until all set screws are engaged into the bottom groove of the body. The top of the set screw should be flush to the body adapter if the body and body adapter are properly aligned. Tighten all screws to 70 ft-lbs torque.
16. Place the body side handle plate over the body and the adapter side handle plate over the adapter body and connect the two plates together with the two threaded studs and four locking nuts. Hand-tighten the locking nuts.
17. Screw the two eyebolts into the tops of the handle plates until they bottom out. Hand-tighten the eyebolts – do not torque.

18. Install one spirolox retaining ring onto one end of the handle tube.
19. Slide one washer onto the handle, insert the handle into both eyebolts, slide the other washer onto the handle and install the second spirolox retaining ring onto the handle.
20. Evaluate the fit of the handle by moving it side to side. If there is more than about 1/16" play, then tap on one or both of the handle plates with a plastic or rubber mallet until the play in the handle is reduced.
21. Torque all four of the locking nuts attached to the threaded studs to complete the handle assembly.
22. Install detachable nut with retainer segments and retainer ring on male sub end of body. Make certain the retainer ring is correctly installed onto the retainer segments and that the retainer ring is fully seated in the groove on the retainer segments.
23. Install seal ring into female sub end of adapter body.

A pressure test to full working pressure should be performed on all rebuilt check valves to ensure proper operations and seal integrity.

4.4 Available Kits

There are two types of kits available for servicing the Dart Check Valves, repair kits and elastomer sets. Table 1 illustrates the kit types for the different valve sizes and their respective part numbers.

Table 1: Dart Check Valve Kits and Part Numbers

Valve Size	Repair Kit	Elastomer Set
1-1/2" 15,000 PSI	P518835	P518834
2" 15,000 PSI		
3" 15,000 PSI	P519874	P519873

Repair Kit: This kit consists of the parts recommended for changing and replacing the dart head. The following parts are included in the repair kit:

Item Description
Polypak Seal
O-ring (Seat)
Seat Seal
O-ring (Environmental)
Helical Coil Spring
Dart Head

Elastomer Set: Order this set when stocking just the internal elastomers. The following parts are included in the elastomer set:

Item Description
Polypak Seal
O-ring (Seat)
Seat Seal
O-ring (Environmental)

5.0 STORAGE INSTRUCTIONS

When not in use, the valve should be stored in an area that protects it from sun, rain, sand, and other debris. Before storing the valve, ensure that the operating fluids have been removed by flushing with water. After cleaning, fully drain all fluids from the valve and spray the valve with a water displacing lubricant such as a Teflon / oil mix. Spray inside both flow bores into the valve as far as possible. Also spray the threads of the union ends. During long term storage keep the valve dry and painted to prevent corrosion.